

4.0	RIDUTTORI A VITE SENZA FINE CON PRECOPPIA H	H HELICAL WORM GEARBOXES	STIRNRAD- SCHNECKENGETRIEBE H	
4.1	Caratteristiche	<i>Characteristics</i>	Merkmale	64
4.2	Designazione	<i>Designation</i>	Bezeichnung	65
4.3	Lubrificazione e posizioni di montaggio	<i>Lubrication and mounting position</i>	Schmierung und Einbaulage	65
4.4	Posizione morsettiera	<i>Terminal board positions</i>	Lage der Klemmenkaste	66
4.5	Dati tecnici	<i>Technical data</i>	Technische Daten	67
4.6	Momenti d'inerzia	<i>Moments of inertia</i>	Trägheitsmoment	74
4.7	Dimensioni	<i>Dimensions</i>	Abmessungen	76
4.8	Esecuzione con vite bisporgente	<i>Double extended worm shaft design</i>	<i>Versionen mit doppelseitig herausragender Schneckenwelle</i>	80
4.9	Limitatore di coppia cavo passante	Torque limiter with through hollow shaft	Drehmomentbegrenzer mit durchgehender Hohlwelle	80
4.10	Accessori	<i>Accessories</i>	Zubehör	82
4.11	Lista parti di ricambio	<i>Spare parts list</i>	Ersatzteilliste	83

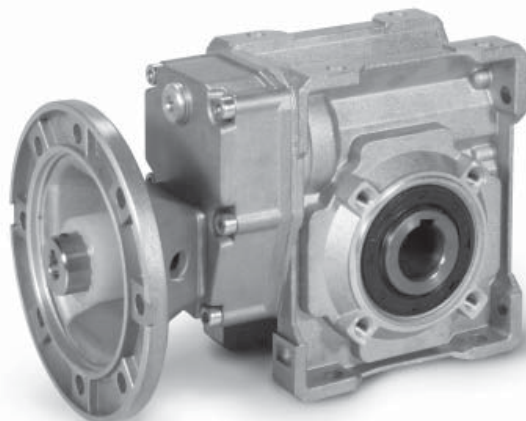

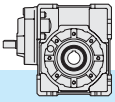

4.1 Caratteristiche

- La serie H presenta le stesse caratteristiche della serie X, ma la presenza della precoppia cilindrica in entrata consente la realizzazione di rapporti più elevati o, a parità di rapporto, rendimenti migliori.
- La struttura è composta dalla carcassa monoblocco del riduttore a vite serie XA sull'entrata del quale è fissato il corpo contenente il primo stadio di riduzione.
- La vite senza fine è in acciaio legato cementato-temprato ed è rettificata.
- Gli ingranaggi della prima riduzione hanno dentatura elicoidale con profilo rettificato.
- La corona ha il mozzo in ghisa con riporto di fusione dell'anello in bronzo.
- Viene fornito l'albero uscita cavo di serie ed esiste un'ampia disponibilità di accessori: seconda entrata, cuscinetti conici sulla corona, flangia uscita, albero lento con 1 o 2 sporgenze, limitatore di coppia con cavo passante, braccio di reazione.
- Le carcasse in ghisa sono verniciate BLU RAL5010 mentre quelle in alluminio sono sabbiate.

4.1 Characteristics

- *The H series has the same characteristics as the X series with the addition of a spur gear pre-stage at input which provides higher ratios or better efficiency under the same ratios.*
- *The structure is composed of a single piece housing for the XA gearbox, at the input side of this gearbox is fitted the housing containing the first stage reduction.*
- *The worm shaft is ground and in case - and quenched alloy steel.*
- *The gears of the first reduction have a helical toothing with ground profile.*
- *The worm wheel has a cast-iron hub provided with inserted cast-bronze ring.*
- *Hollow output shaft is supplied as standard. A broad range of accessories is available: second input, tapered roller bearings on the worm wheel, output flange, single or double extended output shaft, torque limiter with through hollow shaft.*
- *Housings in cast-iron are painted BLUE RAL5010, whereas those in aluminium are sandblasted.*

4.1 Merkmale

- Die Serie H bietet die gleichen Eigenschaften wie die Serie X. Aufgrund der Stirnrad-Vorstufe bei der Serie H sind jedoch höhere Untersetzungen möglich oder man erhält bei gleichen Untersetzungen einen besseren Wirkungsgrad.
- Diese Ausführung besteht aus dem Blockgehäuse des Schneckengetriebes der Serie XA und einem an den antriebsseitig angebauten Gehäuse, welches die Stirnradvorstufe enthält.
- Die Schnecke ist aus einsatzgehärtetem/abgeschrecktem und daraufhin geschliffenen Legierungsstahl.
- Die Zahnräder der Vorstufe besitzen ein schrägverzahntes Stirnradprofil.
- Das Schneckenrad besteht aus einer Nabe aus Gusseisen und einem aufgeschleuderten Gussbronze-Ring.
- Zahlreiches Zubehör ist lieferbar: zweite Antrieb, Kegelrollenlager auf Schneckenrad, Abtriebsflansch, Standard oder doppelseitig herausragende Abtriebswelle, Drehmomentbegrenzer mit durchgehender Welle, Drehmomentstütze.
- Gehäuse aus Gusseisen werden mit BLAU RAL5010 lackiert, Gehäuse aus Aluminium werden sandgestrahlt.

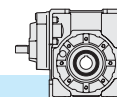

4.2 Designazione

4.2 Designation

4.2 Bezeichnung

Riduttore Gearbox Getriebe	Tipo entrata Input type Antriebsart	Grandezza Size Größe	Rapporto rid. Ratio Untersetzung	Predispos.att. mot. Motor coupling Motoranschluss	Posizione di mont. Mounting position Einbaulage	Flangia in uscita. Output flange Abtriebsflansch	Limitatore di coppia. Torque limiter Drehmomentbegrenzer	Seconda entrata Additional input Zusatzantrieb	Albero uscita Output shaft Abtriebswelle	Braccio di reazione Torque arm Drehmomentstütze
H	A	50	30/1	P.A.M	B3	F1S	LD	SeA	H	BR
Riduttore a vite senza fine Wormgearbox Schneckengetriebe	A F	40 50 63 75 90 110 130	30 40 60 80 100 120 160 200 260 320 400	56 63 71 80 90 100 112	B3, B6 B7, B8 V5, V6	F1D-F2D-F3D F1S-F2S-F3S F12-F22-F32	LD LS	SeA	H SD SS DD	BR

Tipo entrata

Input type

Antriebstyp

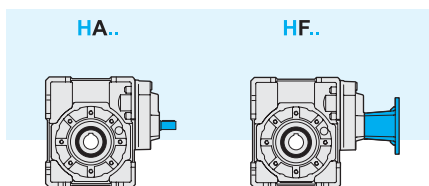

4.3 Lubrificazione e posizioni di montaggio

4.3 Lubrication and mounting position

4.3 Schmierung und Einbaulage

I riduttori a vite senza fine H sono forniti completi di lubrificante sintetico a base PAG con indice di viscosità ISO VG320. Si raccomanda di precisare sempre in fase di ordine, la posizione di lavoro desiderata.

H worm gearboxes are supplied with PAG synthetic lubricant featuring an ISO VG320 viscosity class. Always specify the required mounting position when ordering.

Schneckengetriebe der Serie H werden mit synthetischem Schmiermittel auf PAG Basis und Viskosität Index ISO VG320 geliefert. Im Auftrag bitte immer die gewünschte Einbaulage angeben.

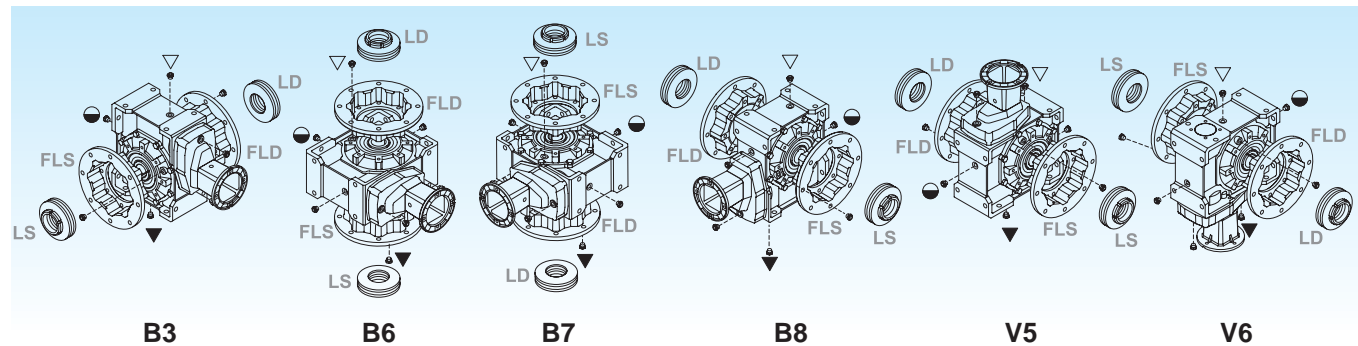

- ▽ Carico e sfiato / Filling and breather
Einfüll und Entlüftung
- Livello / Level / Ölstand
- ▼ Scarico / Drain / Ablass

Nei corpi in alluminio 40, 50, 63,75 è presente un solo tappo di riempimento olio.

Aluminium housings size 40, 50, 63 and 75 have one filling plug only.

Aluminiumgehäuse in den Größen 40, 50, 63 und 75 haben nur eine Einfüllengsschraube

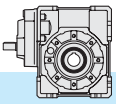

4.3 Lubrificazione e posizioni di montaggio

4.3 Lubrication and mounting position

4.3 Schmierung und Einbaulage

HA
HF V5

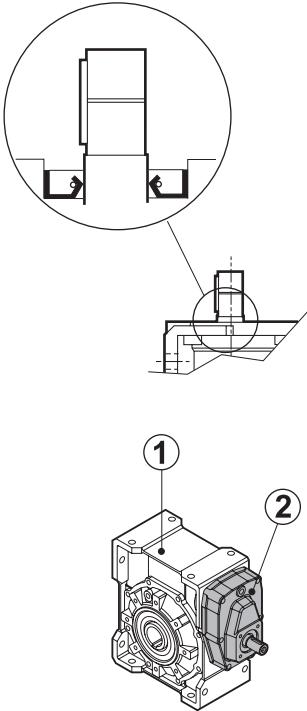

Attenzione! Nelle versioni HA e HF è indispensabile conoscere la posizione di lavoro in quanto nella configurazione V5 occorre posizionare in modo corretto il paraolio della vite per preservare la corretta lubrificazione della coppia d'ingranaggi cilindrici del primo stadio di riduzione.

Warning! It is fundamental to specify the mounting position specially when ordering HA and HF versions. This is because in the V5 configuration the oil seal on the worm shaft must be positioned properly to ensure the lubrication of the spur gearset of the first reduction stage.

Achtung! Bei den HA und HF Versionen ist die Information bez. die Einbaulage unbedingt erforderlich: in der V5 Bauform muss der Ölabdichtung auf der Schnecke korrekt eingebaut werden, um die Schmierung des Stirnradatz der ersten Stufe aufrechtzuhalten.

		Q.tà olio / Oil quantity / Schmiermittelmenge [lt]			
		Posizione di montaggio / Mounting position / Einbaulage			
		B3	B6 - B7	B8	V5 - V6
① H	40	0.040			
	50	0.080			
	63	0.160			
	75	0.260			
	90	1.1	0.9	0.8	1.2
	110	2.2	1.8	1.6	2.4
	130	3.4	3	2.5	3.8
		B3	B6	B8	V5
② H	40	0.040			
	50	0.070			
	63	0.140			
	75	0.200			
	90	0.200			
	110	0.400			
	130	0.350			

Specificare sempre in fase di ordinazione la posizione di montaggio e la forma costruttiva.

Specify the version and the mounting position when ordering.

Bei der Bestellung immer die gewünschte Montageposition und Bauform angeben.

4.4 Posizione morsettiera

4.4 Terminal board position

4.4 Lage der Klemmenkaste

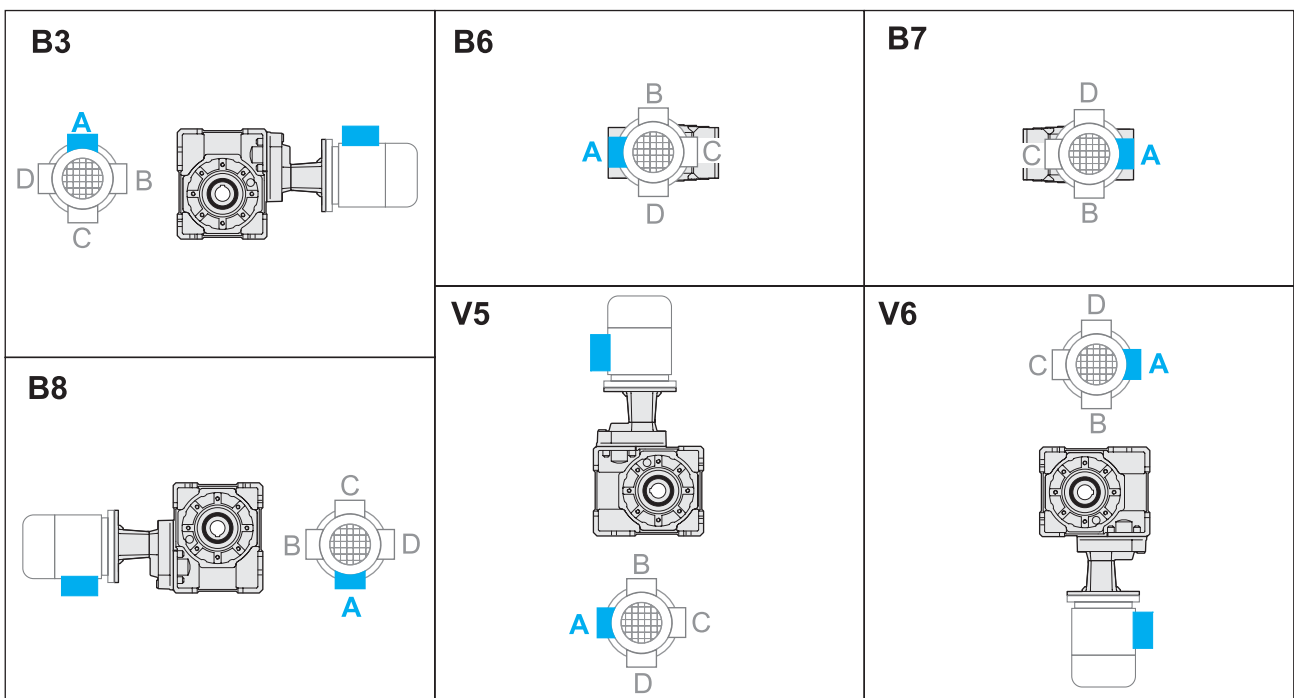

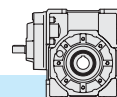

4.5 Dati tecnici

4.5 Technical data

4.5 Technische Daten

40	$n_1 = 2800$				HA		HF								
	i_n	n_2 [min ⁻¹]	Rd	P_{t0}	T_{2M} [Nm]	P [kW]	T_2 [Nm]	P_1 [kW]	FS'	Input - IEC			B14		
	B5			B14											
Kg 2.9	30	93	0.80	—	52	0.64	30	0.37	1.7	—	63	56	—	63	56
	40	70	0.77		53	0.50	39	0.37	1.4						
	60	47	0.72		53	0.36	37	0.25	1.4						
	80	35	0.70		50	0.26	47	0.25	1.1						
	100	28	0.65		44	0.20	40	0.18	1.1						
	120	23	0.61		55	0.22	45	0.18	1.2						
	160	18	0.57		52	0.17	40	0.13	1.3						
	200	14	0.51		47	0.13	47	0.13	1.0						
	260	11	0.47		42	0.10	38	0.09	1.1						
	320	9	0.45		39	0.08	44	0.09	0.9						
400	7	0.42	31	0.05	52*	0.09	0.6*								

40	$n_1 = 1400$				HA		HF								
	i_n	n_2 [min ⁻¹]	Rd	P_{t0}	T_{2M} [Nm]	P [kW]	T_2 [Nm]	P_1 [kW]	FS'	Input - IEC			B14		
	B5			B14											
Kg 2.9	30	47	0.77	0.60	65	0.41	35	0.22	1.9	—	63	56	—	63	56
	40	35	0.75	0.60	65	0.32	45	0.22	1.5						
	60	23	0.69	0.50	62	0.23	62	0.22	1.0						
	80	18	0.66	0.40	60	0.17	47	0.13	1.3						
	100	14	0.61	0.40	52	0.12	46	0.11	1.1						
	120	12	0.57	0.30	66	0.14	60	0.13	1.1						
	160	9	0.52	0.30	62	0.11	62	0.11	1.0						
	200	7	0.47	0.30	58	0.09	58	0.09	1.0						
	260	5	0.43	0.20	46	0.06	46	0.06	1.1						
	320	4	0.41	0.20	44	0.05	53	0.06	0.8						
400	3	0.38	0.20	33	0.03	64*	0.06	0.5*							

40	$n_1 = 900$				HA		HF								
	i_n	n_2 [min ⁻¹]	Rd	P_{t0}	T_{2M} [Nm]	P [kW]	T_2 [Nm]	P_1 [kW]	FS'	Input - IEC			B14		
	B5			B14											
Kg 2.9	30	30	0.76	—	66	0.27	31	0.13	2.1	—	63	56	—	63	56
	40	23	0.73		66	0.21	40	0.13	1.6						
	60	15	0.67		66	0.15	56	0.13	1.2						
	80	11	0.64		66	0.12	49	0.09	1.3						
	100	9	0.59		58	0.09	58	0.09	1.0						
	120	8	0.54		66	0.10	62	0.09	1.1						
	160	6	0.50		66	0.08	51	0.06	1.3						
	200	5	0.44		61	0.06	57	0.06	1.1						
	260	4	0.40		54	0.05	33	0.03	1.6						
	320	3	0.39		46	0.03	39	0.03	1.2						
400	2	0.36	34	0.02	46*	0.03	0.7*								

40	$n_1 = 500$				HA		HF								
	i_n	n_2 [min ⁻¹]	Rd	P_{t0}	T_{2M} [Nm]	P [kW]	T_2 [Nm]	P_1 [kW]	FS'	Input - IEC			B14		
	B5			B14											
Kg 2.9	30	17	0.74	—	66	0.15	—	—	—	—	63	56	—	63	56
	40	13	0.71		66	0.12	—	—	—						
	60	8	0.66		66	0.09	—	—	—						
	80	6	0.62		66	0.07	—	—	—						
	100	5	0.57		66	0.06	—	—	—						
	120	4	0.52		66	0.06	—	—	—						
	160	3	0.48		66	0.04	—	—	—						
	200	2.5	0.42		66	0.04	—	—	—						
	260	2	0.38		60	0.03	—	—	—						
	320	1.5	0.36		48	0.02	—	—	—						
400	1	0.34	35	0.01	—	—	—								

* **ATTENZIONE:** la coppia massima utilizzabile $[T_{2M}]$ deve essere calcolata utilizzando il fattore di servizio: $T_{2M} = T_2 \times FS'$

* **WARNING:** Maximum allowable torque $[T_{2M}]$ must be calculated using the following service factor: $T_{2M} = T_2 \times FS'$

* **ACHTUNG:** das max. anwendbare Drehmoment $[T_{2M}]$ muss mit folgendem Betriebsfaktor berechnet werden: $T_{2M} = T_2 \times FS'$

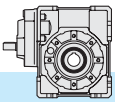

4.5 Dati tecnici

4.5 Technical data

4.5 Technische Daten

50	$n_1 = 2800$				HA		HF								
	i_n	n_2 [min ⁻¹]	Rd	P_{t0}	T_{2M} [Nm]	P [kW]	T_2 [Nm]	P_1 [kW]	FS'	Input - IEC					
										B5			B14		
Kg 4.7	30	93	0.81	—	91	1.10	62	0.75	1.5	71	63	56	71	63	—
	40	70	0.79		94	0.87	81	0.75	1.2						
	60	47	0.74		96	0.63	84	0.55	1.1						
	80	35	0.72		94	0.48	72	0.37	1.3						
	100	28	0.68		81	0.35	58	0.25	1.4						
	120	23	0.64		96	0.37	96	0.37	1.0						
	160	18	0.60		97	0.30	81	0.25	1.2						
	200	14	0.55		86	0.23	67	0.18	1.3						
	260	11	0.51		81	0.18	81	0.18	1.0						
	320	9	0.47		72	0.14	67	0.13	1.1						
	400	7	0.44		59	0.10	54	0.09	1.1						

50	$n_1 = 1400$				HA		HF								
	i_n	n_2 [min ⁻¹]	Rd	P_{t0}	T_{2M} [Nm]	P [kW]	T_2 [Nm]	P_1 [kW]	FS'	Input - IEC					
										B5			B14		
Kg 4.7	30	47	0.79	0.90	113	0.70	88	0.55	1.3	71	63	56	71	63	—
	40	35	0.76	0.80	116	0.56	116	0.55	1.0						
	60	23	0.71	0.70	116	0.40	108	0.37	1.1						
	80	18	0.68	0.60	114	0.31	93	0.25	1.2						
	100	14	0.63	0.50	97	0.22	97	0.22	1.0						
	120	12	0.59	0.50	107	0.22	107	0.22	1.0						
	160	9	0.55	0.40	115	0.19	108	0.18	1.1						
	200	7	0.50	0.40	102	0.15	89	0.13	1.1						
	260	5	0.46	0.40	90	0.11	90	0.11	1.0						
	320	4	0.42	0.30	83	0.09	83	0.09	1.0						
	400	3	0.40	0.30	65	0.06	65	0.06	0.9						

50	$n_1 = 900$				HA		HF								
	i_n	n_2 [min ⁻¹]	Rd	P_{t0}	T_{2M} [Nm]	P [kW]	T_2 [Nm]	P_1 [kW]	FS'	Input - IEC					
										B5			B14		
Kg 4.7	30	30	0.77	—	116	0.47	91	0.37	1.3	71	63	56	71	63	—
	40	23	0.75		116	0.37	116	0.37	1.0						
	60	15	0.69		116	0.26	110	0.25	1.1						
	80	11	0.66		116	0.21	101	0.18	1.2						
	100	9	0.61		108	0.17	85	0.13	1.3						
	120	8	0.57		116	0.16	94	0.13	1.3						
	160	6	0.53		116	0.13	116	0.13	1.0						
	200	5	0.48		112	0.11	91	0.09	1.2						
	260	4	0.44		107	0.09	107	0.09	1.0						
	320	3	0.40		90	0.07	82	0.06	1.1						
	400	2	0.38		65	0.04	48	0.03	1.4						

50	$n_1 = 500$				HA		HF								
	i_n	n_2 [min ⁻¹]	Rd	P_{t0}	T_{2M} [Nm]	P [kW]	T_2 [Nm]	P_1 [kW]	FS'	Input - IEC					
										B5			B14		
Kg 4.7	30	17	0.76	—	116	0.27	39	0.09	3.0	71	63	56	71	63	—
	40	13	0.73		116	0.21	50	0.09	2.3						
	60	8	0.67		116	0.15	69	0.09	1.7						
	80	6	0.64		116	0.12	88	0.09	1.3						
	100	5	0.59		116	0.10	101	0.09	1.1						
	120	4	0.54		116	0.09	112	0.09	1.0						
	160	3	0.50		116	0.08	138*	0.09	0.8						
	200	2.5	0.45		116	0.07	156*	0.09	0.7						
	260	2	0.41		114	0.06	184*	0.09	0.6*						
	320	1.5	0.38		95	0.04	208*	0.09	0.5*						
	400	1	0.35		69	0.03	244*	0.09	0.3*						

* **ATTENZIONE:** la coppia massima utilizzabile $[T_{2M}]$ deve essere calcolata utilizzando il fattore di servizio: $T_{2M} = T_2 \times FS'$

* **WARNING:** Maximum allowable torque $[T_{2M}]$ must be calculated using the following service factor: $T_{2M} = T_2 \times FS'$

* **ACHTUNG:** das max. anwendbare Drehmoment $[T_{2M}]$ muss mit folgendem Betriebsfaktor berechnet werden: $T_{2M} = T_2 \times FS'$

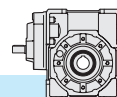

4.5 Dati tecnici

4.5 Technical data

4.5 Technische Daten

63	$n_1 = 2800$				HA		HF								
	i_n	n_2 [min ⁻¹]	Rd	P_{t0}	T_{2M} [Nm]	P [kW]	T_2 [Nm]	P_1 [kW]	FS'	Input - IEC			B14		
											B5				
Kg 7.9	30	93	0.82	—	158	1.89	126	1.5	1.3	80	71	63	80	71	—
	40	70	0.80		164	1.50	164	1.5	1.0						
	60	47	0.76		170	1.10	170	1.1	1.0						
	80	35	0.74		181	0.90	151	0.75	1.2						
	100	28	0.71		150	0.62	133	0.55	1.1						
	120	23	0.66		177	0.66	148	0.55	1.2						
	160	18	0.62		186	0.55	186	0.55	1.0						
	200	14	0.57		147	0.37	147	0.37	1.0						
	260	11	0.53		142	0.30	118	0.25	1.2						
	320	9	0.51		138	0.25	138	0.25	1.0						
	400	7	0.46		115	0.18	115	0.18	1.0						

63	$n_1 = 1400$				HA		HF								
	i_n	n_2 [min ⁻¹]	Rd	P_{t0}	T_{2M} [Nm]	P [kW]	T_2 [Nm]	P_1 [kW]	FS'	Input - IEC			B14		
											B5				
Kg 7.9	30	47	0.79	1.3	198	1.22	146	0.9	1.4	80	71	63	80	71	—
	40	35	0.77	1.2	203	0.96	190	0.9	1.1						
	60	23	0.72	1.0	203	0.69	163	0.55	1.2						
	80	18	0.70	0.90	211	0.55	211	0.55	1.0						
	100	14	0.67	0.80	181	0.40	169	0.37	1.1						
	120	12	0.61	0.70	213	0.43	185	0.37	1.1						
	160	9	0.57	0.60	220	0.35	156	0.25	1.4						
	200	7	0.52	0.60	177	0.25	177	0.25	1.0						
	260	5	0.48	0.50	175	0.20	154	0.18	1.1						
	320	4	0.46	0.50	160	0.16	130	0.13	1.2						
	400	3	0.41	0.50	126	0.11	150	0.13	0.8						

63	$n_1 = 900$				HA		HF								
	i_n	n_2 [min ⁻¹]	Rd	P_{t0}	T_{2M} [Nm]	P [kW]	T_2 [Nm]	P_1 [kW]	FS'	Input - IEC			B14		
											B5				
Kg 7.9	30	30	0.78	—	220	0.89	186	0.75	1.2	80	71	63	80	71	—
	40	23	0.76		220	0.69	177	0.55	1.2						
	60	15	0.70		220	0.49	166	0.37	1.3						
	80	11	0.68		220	0.37	220	0.37	1.0						
	100	9	0.65		201	0.29	172	0.25	1.2						
	120	8	0.59		220	0.29	187	0.25	1.2						
	160	6	0.55		220	0.24	168	0.18	1.3						
	200	5	0.50		196	0.18	196	0.18	1.0						
	260	4	0.46		192	0.15	162	0.13	1.2						
	320	3	0.43		175	0.12	133	0.09	1.3						
	400	2	0.39		131	0.08	148	0.09	0.9						

63	$n_1 = 500$				HA		HF								
	i_n	n_2 [min ⁻¹]	Rd	P_{t0}	T_{2M} [Nm]	P [kW]	T_2 [Nm]	P_1 [kW]	FS'	Input - IEC			B14		
											B5				
Kg 7.9	30	17	0.76	—	220	0.50	79	0.18	2.8	80	71	63	80	71	—
	40	13	0.74		220	0.39	101	0.18	2.2						
	60	8	0.68		220	0.28	140	0.18	1.6						
	80	6	0.66		220	0.22	182	0.18	1.2						
	100	5	0.62		220	0.18	220	0.18	1.0						
	120	4	0.56		220	0.17	115	0.09	1.9						
	160	3	0.52		220	0.14	143	0.09	1.5						
	200	2.5	0.47		220	0.12	161	0.09	1.4						
	260	2	0.43		215	0.10	193	0.09	1.1						
	320	1.5	0.41		188	0.08	225	0.09	0.8						
	400	1	0.36		138	0.05	250*	0.09	0.6*						

* **ATTENZIONE:** la coppia massima utilizzabile $[T_{2M}]$ deve essere calcolata utilizzando il fattore di servizio: $T_{2M} = T_2 \times FS'$

* **WARNING:** Maximum allowable torque $[T_{2M}]$ must be calculated using the following service factor: $T_{2M} = T_2 \times FS'$

* **ACHTUNG:** das max. anwendbare Drehmoment $[T_{2M}]$ muss mit folgendem Betriebsfaktor berechnet werden: $T_{2M} = T_2 \times FS'$

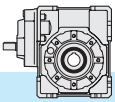

4.5 Dati tecnici

4.5 Technical data

4.5 Technische Daten

75	$n_1 = 2800$				HA		HF								
	i_n	n_2 [min ⁻¹]	Rd	P_{t0}	T_{2M} [Nm]	P [kW]	T_2 [Nm]	P_1 [kW]	FS'	Input - IEC					
										B5		B14			
Kg 13.3	30	93	0.82	—	236	2.81	185	2.2	1.3	90	80	71	90	80	—
	40	70	0.80		242	2.20	242	2.2	1.0						
	60	47	0.77		258	1.65	235	1.5	1.1						
	80	35	0.74		285	1.40	223	1.1	1.3						
	100	28	0.72		252	1.03	184	0.75	1.4						
	120	23	0.67		275	1.01	205	0.75	1.3						
	160	18	0.63		290	0.84	259	0.75	1.1						
	200	14	0.60		258	0.63	224	0.55	1.2						
	260	11	0.55		236	0.48	181	0.37	1.3						
	320	9	0.52		214	0.37	214	0.37	1.0						
	400	7	0.48		195	0.30	241	0.37	0.8						

75	$n_1 = 1400$				HA		HF								
	i_n	n_2 [min ⁻¹]	Rd	P_{t0}	T_{2M} [Nm]	P [kW]	T_2 [Nm]	P_1 [kW]	FS'	Input - IEC					
										B5		B14			
Kg 13.3	30	47	0.80	1.9	295	1.80	295	1.8	1.0	90	80	71	90	80	—
	40	35	0.78	1.7	319	1.50	319	1.5	1.0						
	60	23	0.73	1.4	329	1.10	329	1.1	1.0						
	80	18	0.71	1.3	350	0.90	350	0.9	1.0						
	100	14	0.68	1.2	305	0.66	255	0.55	1.2						
	120	12	0.62	1.0	331	0.65	280	0.55	1.2						
	160	9	0.58	0.90	348	0.55	348	0.55	1.0						
	200	7	0.55	0.80	307	0.41	277	0.37	1.1						
	260	5	0.50	0.80	279	0.31	223	0.25	1.3						
	320	4	0.47	0.70	256	0.25	256	0.25	1.0						
	400	3	0.43	0.70	213	0.18	300*	0.25	0.7*						

75	$n_1 = 900$				HA		HF								
	i_n	n_2 [min ⁻¹]	Rd	P_{t0}	T_{2M} [Nm]	P [kW]	T_2 [Nm]	P_1 [kW]	FS'	Input - IEC					
										B5		B14			
Kg 13.3	30	30	0.78	—	338	1.35	275	1.1	1.2	90	80	71	90	80	—
	40	23	0.76		350	1.10	350	1.1	1.0						
	60	15	0.71		343	0.75	343	0.75	1.0						
	80	11	0.69		350	0.60	321	0.55	1.1						
	100	9	0.66		339	0.49	258	0.37	1.3						
	120	8	0.60		350	0.46	281	0.37	1.2						
	160	6	0.56		350	0.37	350	0.37	1.0						
	200	5	0.52		339	0.31	277	0.25	1.2						
	260	4	0.48		307	0.24	233	0.18	1.3						
	320	3	0.45		282	0.18	282	0.18	1.0						
	400	2	0.40		221	0.13	307*	0.18	0.7*						

75	$n_1 = 500$				HA		HF								
	i_n	n_2 [min ⁻¹]	Rd	P_{t0}	T_{2M} [Nm]	P [kW]	T_2 [Nm]	P_1 [kW]	FS'	Input - IEC					
										B5		B14			
Kg 13.3	30	17	0.77	—	350	0.80	110	0.25	3.2	90	80	71	90	80	—
	40	13	0.74		350	0.62	142	0.25	2.5						
	60	8	0.69		350	0.44	198	0.25	1.8						
	80	6	0.67		350	0.34	254	0.25	1.4						
	100	5	0.63		350	0.29	303	0.25	1.2						
	120	4	0.57		350	0.27	325	0.25	1.1						
	160	3	0.53		350	0.22	291	0.18	1.2						
	200	2.5	0.49		350	0.19	348	0.18	1.0						
	260	2	0.45		345	0.16	200	0.09	1.7						
	320	1.5	0.42		303	0.12	231	0.09	1.3						
	400	1	0.38		232	0.08	258	0.09	0.9						

* **ATTENZIONE:** la coppia massima utilizzabile $[T_{2M}]$ deve essere calcolata utilizzando il fattore di servizio: $T_{2M} = T_2 \times FS'$

* **WARNING:** Maximum allowable torque $[T_{2M}]$ must be calculated using the following service factor: $T_{2M} = T_2 \times FS'$

* **ACHTUNG:** das max. anwendbare Drehmoment $[T_{2M}]$ muss mit folgendem Betriebsfaktor berechnet werden: $T_{2M} = T_2 \times FS'$



4.5 Dati tecnici

4.5 Technical data

4.5 Technische Daten

90	$n_1 = 2800$				HA		HF								
	i_n	n_2 [min ⁻¹]	Rd	P_{t0}	T_{2M} [Nm]	P [kW]	T_2 [Nm]	P_1 [kW]	FS'	Input - IEC			B14		
											B5				
 27.2	30	93	0.83	—	381	4.48	255	3	1.5	90	80	71	90	80	—
	40	70	0.82		396	3.56	334	3	1.2						
	60	47	0.78		410	2.57	352	2.2	1.2						
	80	35	0.76		456	2.20	456	2.2	1.0						
	100	28	0.74		416	1.66	377	1.5	1.1						
	120	23	0.69		439	1.54	439	1.5	1.0						
	160	18	0.65		467	1.31	392	1.1	1.2						
	200	14	0.62		427	1.01	317	0.75	1.3						
	260	11	0.58		384	0.75	384	0.75	1.0						
	320	9	0.55		360	0.60	329	0.55	1.1						
400	7	0.50	318	0.47	252	0.37	1.3								

90	$n_1 = 1400$				HA		HF								
	i_n	n_2 [min ⁻¹]	Rd	P_{t0}	T_{2M} [Nm]	P [kW]	T_2 [Nm]	P_1 [kW]	FS'	Input - IEC			B14		
											B5				
 27.2	30	47	0.81	2.1	482	2.92	297	1.8	1.6	90	80	71	90	80	—
	40	35	0.79	1.9	495	2.30	388	1.8	1.3						
	60	23	0.75	1.6	506	1.65	460	1.5	1.1						
	80	18	0.72	1.4	554	1.40	434	1.1	1.3						
	100	14	0.70	1.3	505	1.06	429	0.9	1.2						
	120	12	0.64	1.1	531	1.01	473	0.9	1.1						
	160	9	0.60	1.0	560	0.85	494	0.75	1.1						
	200	7	0.57	0.90	510	0.66	428	0.55	1.2						
	260	5	0.53	0.80	454	0.49	345	0.37	1.3						
	320	4	0.50	0.80	424	0.39	402	0.37	1.1						
400	3	0.45	0.70	367	0.29	314	0.25	1.2							

90	$n_1 = 900$				HA		HF								
	i_n	n_2 [min ⁻¹]	Rd	P_{t0}	T_{2M} [Nm]	P [kW]	T_2 [Nm]	P_1 [kW]	FS'	Input - IEC			B14		
											B5				
 27.2	30	30	0.79	—	550	2.18	379	1.5	1.5	90	80	71	90	80	—
	40	23	0.77		560	1.71	492	1.5	1.1						
	60	15	0.73		560	1.21	510	1.1	1.1						
	80	11	0.70		560	0.94	447	0.75	1.3						
	100	9	0.68		560	0.78	534	0.75	1.1						
	120	8	0.61		560	0.72	430	0.55	1.3						
	160	6	0.58		560	0.57	533	0.55	1.1						
	200	5	0.54		560	0.49	426	0.37	1.3						
	260	4	0.50		501	0.37	501	0.37	1.0						
	320	3	0.47		466	0.29	399	0.25	1.2						
400	2	0.42	381	0.21	320	0.18	1.2								

90	$n_1 = 500$				HA		HF								
	i_n	n_2 [min ⁻¹]	Rd	P_{t0}	T_{2M} [Nm]	P [kW]	T_2 [Nm]	P_1 [kW]	FS'	Input - IEC			B14		
											B5				
 27.2	30	17	0.77	—	560	1.26	111	0.25	5.0	90	80	71	90	80	—
	40	13	0.75		560	0.97	144	0.25	3.9						
	60	8	0.70		560	0.69	202	0.25	2.8						
	80	6	0.68		560	0.54	259	0.25	2.2						
	100	5	0.65		560	0.45	310	0.25	1.8						
	120	4	0.58		560	0.42	334	0.25	1.7						
	160	3	0.54		560	0.34	416	0.25	1.3						
	200	2.5	0.51		560	0.29	488	0.25	1.1						
	260	2	0.47		560	0.24	417	0.18	1.3						
	320	1.5	0.44		517	0.19	485	0.18	1.1						
400	1	0.39	401	0.13	269	0.09	1.5								

* **ATTENZIONE:** la coppia massima utilizzabile [T_{2M}] deve essere calcolata utilizzando il fattore di servizio: $T_{2M} = T_2 \times FS'$

* **WARNING:** Maximum allowable torque [T_{2M}] must be calculated using the following service factor: $T_{2M} = T_2 \times FS'$

* **ACHTUNG:** das max. anwendbare Drehmoment [T_{2M}] muss mit folgendem Betriebsfaktor berechnet werden: $T_{2M} = T_2 \times FS'$

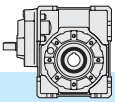

4.5 Dati tecnici

4.5 Technical data

4.5 Technische Daten

110	$n_1 = 2800$				HA		HF								
	i_n	n_2 [min ⁻¹]	Rd	P_{t0}	T_{2M} [Nm]	P [kW]	T_2 [Nm]	P_1 [kW]	FS'	Input - IEC					
										B5		B14			
48.8	30	93	0.84	—	641	7.50	641	7.5	1.0	112 100	90	80	112 100	90	—
	40	70	0.82		658	5.85	619	5.5	1.1						
	60	47	0.79		698	4.30	649	4	1.1						
	80	35	0.77		782	3.71	632	3	1.2						
	100	28	0.75		727	2.83	566	2.2	1.3						
	120	23	0.70		754	2.61	634	2.2	1.2						
	160	18	0.67		807	2.20	807	2.2	1.0						
	200	14	0.65		749	1.70	661	1.5	1.1						
	260	11	0.60		646	1.21	589	1.1	1.1						
	320	9	0.57		611	0.98	469	0.75	1.3						
400	7	0.53	545	0.75	545	0.75	1.0								

110	$n_1 = 1400$				HA		HF								
	i_n	n_2 [min ⁻¹]	Rd	P_{t0}	T_{2M} [Nm]	P [kW]	T_2 [Nm]	P_1 [kW]	FS'	Input - IEC					
										B5		B14			
48.8	30	47	0.82	3.2	807	4.83	668	4	1.2	112 100	90	80	112 100	90	—
	40	35	0.80	2.9	825	3.78	655	3	1.3						
	60	23	0.76	2.4	864	2.76	689	2.2	1.3						
	80	18	0.74	2.2	957	2.37	887	2.2	1.1						
	100	14	0.72	2.1	884	1.80	884	1.8	1.0						
	120	12	0.66	1.7	916	1.70	809	1.5	1.1						
	160	9	0.62	1.5	970	1.42	749	1.1	1.3						
	200	7	0.60	1.5	896	1.10	896	1.1	1.0						
	260	5	0.55	1.3	743	0.75	743	0.75	1.0						
	320	4	0.52	1.2	722	0.64	624	0.55	1.2						
400	3	0.47	1.1	644	0.48	705	0.55	0.9							

110	$n_1 = 900$				HA		HF								
	i_n	n_2 [min ⁻¹]	Rd	P_{t0}	T_{2M} [Nm]	P [kW]	T_2 [Nm]	P_1 [kW]	FS'	Input - IEC					
										B5		B14			
48.8	30	30	0.80	—	922	3.61	766	3	1.2	112 100	90	80	112 100	90	—
	40	23	0.78		937	2.82	732	2.2	1.3						
	60	15	0.74		970	2.06	849	1.8	1.1						
	80	11	0.72		970	1.59	912	1.5	1.1						
	100	9	0.69		970	1.32	811	1.1	1.2						
	120	8	0.63		970	1.21	884	1.1	1.1						
	160	6	0.60		970	0.96	758	0.75	1.3						
	200	5	0.57		970	0.81	902	0.75	1.1						
	260	4	0.52		846	0.60	779	0.55	1.1						
	320	3	0.49		794	0.48	616	0.37	1.3						
400	2	0.45	700	0.37	700	0.37	1.0								

110	$n_1 = 500$				HA		HF								
	i_n	n_2 [min ⁻¹]	Rd	P_{t0}	T_{2M} [Nm]	P [kW]	T_2 [Nm]	P_1 [kW]	FS'	Input - IEC					
										B5		B14			
48.8	30	17	0.78	—	970	2.16	336	0.75	2.9	112 100	90	80	112 100	90	—
	40	13	0.76		970	1.67	437	0.75	2.2						
	60	8	0.72		970	1.18	616	0.75	1.6						
	80	6	0.69		970	0.92	792	0.75	1.2						
	100	5	0.67		970	0.75	970	0.75	1.0						
	120	4	0.60		970	0.71	754	0.55	1.3						
	160	3	0.56		970	0.57	933	0.55	1.1						
	200	2.5	0.53		970	0.48	754	0.37	1.3						
	260	2	0.49		955	0.39	900	0.37	1.1						
	320	1.5	0.46		889	0.32	700	0.25	1.3						
400	1	0.41	727	0.23	568	0.18	1.3								

* **ATTENZIONE:** la coppia massima utilizzabile $[T_{2M}]$ deve essere calcolata utilizzando il fattore di servizio: $T_{2M} = T_2 \times FS'$

* **WARNING:** Maximum allowable torque $[T_{2M}]$ must be calculated using the following service factor: $T_{2M} = T_2 \times FS'$

* **ACHTUNG:** das max. anwendbare Drehmoment $[T_{2M}]$ muss mit folgendem Betriebsfaktor berechnet werden: $T_{2M} = T_2 \times FS'$

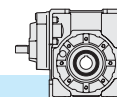

4.5 Dati tecnici

4.5 Technical data

4.5 Technische Daten

130	$n_1 = 2800$				HA			HF					
	i_n	n_2 [min ⁻¹]	Rd	P_{t0}	T_{2M} [Nm]	P [kW]	T_2 [Nm]	P_1 [kW]	FS'	Input - IEC			B14
											B5		
	30	93	0.85	—	976	11.22	652	7.5	1.5	112 100	90	80	—
	40	70	0.84		994	8.67	860	7.5	1.2				
	60	47	0.80		1086	6.63	900	5.5	1.2				
	80	35	0.78		1216	5.71	1171	5.5	1.0				
	100	28	0.78		1170	4.40	1064	4.0	1.1				
	120	23	0.72		1203	4.08	1179	4	1.0				
	160	18	0.70		1306	3.42	1146	3	1.1				
	200	14	0.67		1175	2.57	1005	2.2	1.2				
	260	11	0.64		1008	1.78	851	1.5	1.2				
	320	9	0.61		971	1.46	732	1.1	1.3				
	400	7	0.57		889	1.14	855	1.1	1.0				

130	$n_1 = 1400$				HA			HF					
	i_n	n_2 [min ⁻¹]	Rd	P_{t0}	T_{2M} [Nm]	P [kW]	T_2 [Nm]	P_1 [kW]	FS'	Input - IEC			B14
											B5		
	30	47	0.83	4.9	1231	7.3	928	5.5	1.3	112 100	90	80	—
	40	35	0.81	4.4	1238	5.6	1216	5.5	1.0				
	60	23	0.77	3.6	1375	4.3	1279	4	1.1				
	80	18	0.75	3.3	1472	3.7	1194	3	1.2				
	100	14	0.74	3.2	1413	2.8	1111	2.2	1.3				
	120	12	0.68	2.6	1407	2.6	1191	2.2	1.2				
	160	9	0.65	2.4	1517	2.2	1517	2.2	1.0				
	200	7	0.62	2.2	1353	1.6	1269	1.5	1.1				
	260	5	0.58	2	1219	1.1	1219	1.1	1.0				
	320	4	0.55	1.8	1182	0.9	1182	0.9	1.0				
	400	3	0.51	1.7	1136	0.7	893	0.55	1.3				

130	$n_1 = 900$				HA			HF					
	i_n	n_2 [min ⁻¹]	Rd	P_{t0}	T_{2M} [Nm]	P [kW]	T_2 [Nm]	P_1 [kW]	FS'	Input - IEC			B14
											B5		
	30	30	0.81	—	1424	5.5	774	3	1.8	112 100	90	80	—
	40	23	0.80		1429	4.2	1019	3	1.4				
	60	15	0.75		1520	3.2	1433	3	1.1				
	80	11	0.72		1694	2.8	1345	2.2	1.3				
	100	9	0.72		1726	2.3	1681	2.2	1.0				
	120	8	0.64		1632	2.0	1508	1.85	1.1				
	160	6	0.61		1723	1.7	1553	1.5	1.1				
	200	5	0.58		1542	1.3	1354	1.1	1.1				
	260	4	0.54		1282	0.87	1102	0.75	1.2				
	320	3	0.51		1298	0.75	1299	0.75	1.0				
	400	2	0.47		1126	0.56	1097	0.55	1.0				

130	$n_1 = 500$				HA			HF					
	i_n	n_2 [min ⁻¹]	Rd	P_{t0}	T_{2M} [Nm]	P [kW]	T_2 [Nm]	P_1 [kW]	FS'	Input - IEC			B14
											B5		
	30	17	0.78	—	1659	3.7	335	0.75	4.9	112 100	90	80	—
	40	13	0.76		1616	2.8	435	0.75	3.7				
	60	8	0.72		1786	2.2	619	0.75	2.9				
	80	6	0.70		1819	1.7	802	0.75	2.3				
	100	5	0.69		1821	1.4	988	0.75	1.8				
	120	4	0.61		1816	1.3	1049	0.75	1.7				
	160	3	0.57		1796	1.0	1306	0.75	1.4				
	200	2.5	0.54		1723	0.84	1547	0.75	1.1				
	260	2	0.50		1485	0.60	1366	0.55	1.1				
	320	1.5	0.47		1392	0.48	1063	0.37	1.3				
	400	1	0.44		1282	0.38	1244	0.37	1.0				

* **ATTENZIONE:** la coppia massima utilizzabile $[T_{2M}]$ deve essere calcolata utilizzando il fattore di servizio: $T_{2M} = T_2 \times FS'$

* **WARNING:** Maximum allowable torque $[T_{2M}]$ must be calculated using the following service factor: $T_{2M} = T_2 \times FS'$

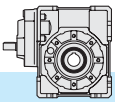

* **ACHTUNG:** das max. anwendbare Drehmoment $[T_{2M}]$ muss mit folgendem Betriebsfaktor berechnet werden: $T_{2M} = T_2 \times FS'$







4.6 **Momenti d' inerzia** [Kg.cm²]
(riferiti all'albero veloce in entrata)



4.6 **Moments of inertia** [Kg.cm²]
(referred to input shaft)

4.6 **Trägheitsmoment** [Kg.cm²]
(bez. Antriebswelle)

H40	i _n	HA 	HF 	
			B5 - B14	
			IEC 56	IEC 63
30	0.080	0.125	0.125	
40	0.079	0.123	0.124	
60	0.077	0.122	0.123	
80	0.076	0.120	0.121	
100	0.075	0.120	0.120	
120	0.077	0.121	0.122	
160	0.075	0.120	0.120	
200	0.075	0.120	0.120	
260	0.074	0.119	0.119	
320	0.074	0.119	0.119	
400	0.074	0.119	0.119	

H50	i _n	HA 	HF 		
			B5	B5 - B14	
			IEC 56	IEC 63	IEC 71
30	0.161	0.208	0.366	0.383	
40	0.156	0.203	0.361	0.377	
60	0.152	0.199	0.357	0.374	
80	0.148	0.194	0.352	0.369	
100	0.147	0.194	0.352	0.368	
120	0.150	0.197	0.355	0.372	
160	0.146	0.193	0.351	0.368	
200	0.141	0.188	0.346	0.363	
260	0.138	0.185	0.343	0.360	
320	0.138	0.185	0.343	0.360	
400	0.138	0.185	0.343	0.360	

H63	i _n	HA 	HF 		
			B5	B5 - B14	
			IEC 63	IEC 71	IEC 80
30	0.405	0.639	0.656	1.219	
40	0.392	0.626	0.643	1.206	
60	0.383	0.617	0.634	1.197	
80	0.364	0.598	0.615	1.178	
100	0.362	0.596	0.613	1.176	
120	0.377	0.612	0.628	1.191	
160	0.361	0.595	0.612	1.175	
200	0.360	0.595	0.611	1.175	
260	0.354	0.588	0.605	1.168	
320	0.354	0.588	0.605	1.168	
400	0.354	0.588	0.605	1.168	

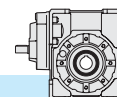

H75	i _n	HA 	HF 		
			B5	B5 - B14	
			IEC 71	IEC 80	IEC 90
30	0.865	1.643	1.778	2.855	
40	0.835	1.613	1.748	2.825	
60	0.813	1.592	1.726	2.804	
80	0.777	1.556	1.690	2.768	
100	0.773	1.551	1.686	2.764	
120	0.801	1.579	1.714	2.791	
160	0.770	1.548	1.683	2.760	
200	0.769	1.547	1.682	2.759	
260	0.751	1.530	1.664	2.742	
320	0.751	1.530	1.664	2.742	
400	0.751	1.529	1.664	2.742	







4.6 **Momenti d' inerzia** [Kg.cm²]
(riferiti all'albero veloce in entrata)

4.6 **Moments of inertia** [Kg.cm²]
(referred to input shaft)

4.6 **Trägheitsmoment** [Kg.cm²]
(bez. Antriebswelle)

H90	i _n	HA 	HF 		
			B5		
			IEC 71	IEC 80	IEC 90
	30	1.064	1.843	1.977	3.055
	40	1.000	1.779	1.913	2.991
	60	0.955	1.733	1.868	2.945
	80	0.845	1.623	1.758	2.835
	100	0.836	1.615	1.749	2.827
	120	0.927	1.706	1.840	2.918
	160	0.829	1.608	1.742	2.820
	200	0.827	1.606	1.740	2.818
	260	0.784	1.562	1.696	2.774
	320	0.783	1.562	1.696	2.774
	400	0.783	1.561	1.695	2.773

H110	i _n	HA 	HF 		
			B5		
			IEC 80	IEC 90	IEC 110-112
	30	2.558	4.726	4.654	6.424
	40	2.379	4.547	4.475	6.246
	60	2.251	4.420	4.347	6.118
	80	1.958	4.127	4.054	5.825
	100	1.933	4.102	4.029	5.800
	120	2.175	4.343	4.271	6.041
	160	1.915	4.084	4.011	5.782
	200	1.909	4.077	4.005	5.776
	260	1.779	3.948	3.875	5.646
	320	1.778	3.946	3.874	5.645
	400	1.777	3.945	3.873	5.644

H130	i _n	HA 	HF 		
			B5		
			IEC 80	IEC 90	IEC 110-112
	30	5.64	7.90	10.22	11.83
	40	5.15	7.42	9.73	11.35
	60	4.81	7.07	9.39	11.00
	80	4.15	6.41	8.72	10.34
	100	4.07	6.34	8.65	10.27
	120	4.60	6.86	9.18	10.79
	160	4.03	6.29	8.61	10.22
	200	4.01	6.27	8.59	10.20
	260	3.75	6.01	8.32	9.94
	320	3.74	6.00	8.32	9.93
	400	3.74	6.00	8.32	9.93

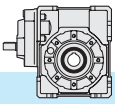

HA

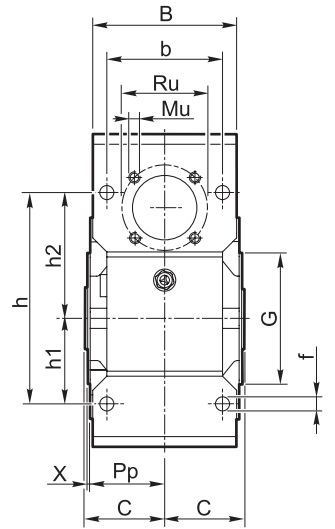
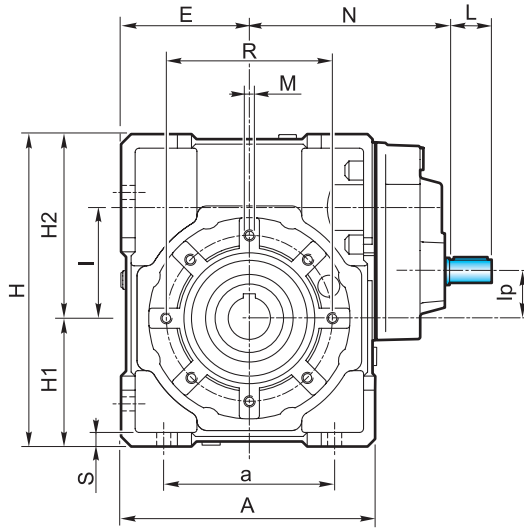

HF

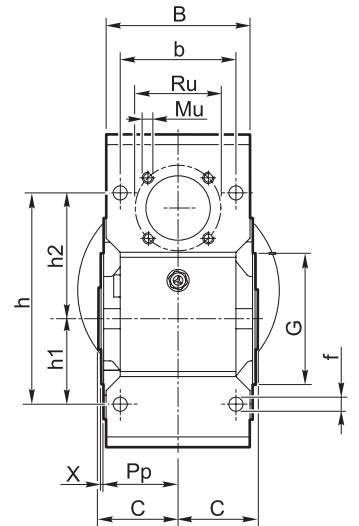
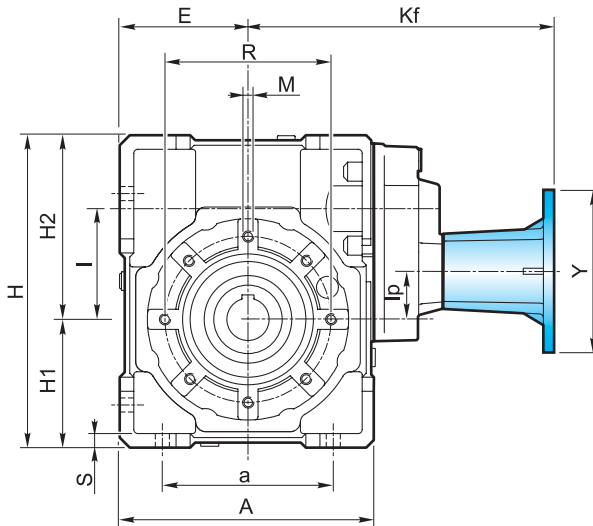

Flangia pendolare / Shaft-mounted flange / Aufsteckflansch

40 - 50

63 - 75 - 90 - 110 - 130

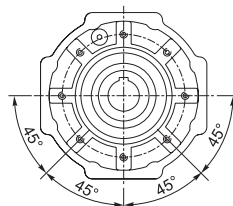
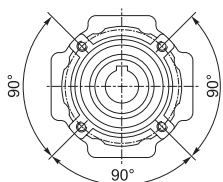

4 Fori / Holes / Bohrungen

8 Fori / Holes / Bohrungen



Albero uscita cavo
Output hollow shaft
Abtriebshohlwelle

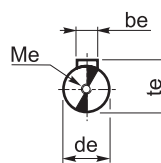

Albero entrata
Input shaft
Antriebswelle

H	A	a	B	b	b _e	b ₂	C	d _e j ₆	D ₂ H ₇	E	f	G h ₈	H	H ₁	H ₂	h	h ₁	h ₂		
40	105	70	71	60	3	6	6	39	9	18	19	50	6.5	60	125	50	75	90	35	55
50	125	80	85	70	4	8	8	46	11	25	24	60	8.5	70	150	60	90	104	40	64
63	147	100	103	85	5	8	—	56	14	25	—	72	9	80	182	72	110	130	50	80
75	176	120	112	90	6	8	8	60	19	28	30	86	11	95	219.5	86	133.5	153	60	93
90	203	140	130	100	6	10	—	70	19	35	—	103	13	110	248.5	103	145.5	172	70	102
110	252.5	170	143	115	8	12	—	77.5	24	42	—	127.5	14	130	310.5	127.5	183	210	85	125
130	292.5	200	155	120	8	14	14	85	24	45	48	147.5	15	180	355	147.5	207.5	240	100	140

H	I	I _p	L	M	M _e	M _u	N	P _p	R	R _u	S	t _e	t ₂	X	
40	40	5	15	M6X10	M4X12	M5X10	91.5	36.5	75	42.4	6	10.2	20.8	21.8	1.5
50	50	10	20	M8x10	M4x12	M6x10	104.5	43.5	85	53.7	7	12.5	28.3	27.3	1.5
63	63	16.5	25	M8x14	M4x10	M6x12	121	53	95	60.8	8	16	28.3	—	2
75	75	22	30	M8x14	M6x16	M8x12	147.75	57	115	70.7	10	21.5	31.3	33.3	2
90	90	37	30	M10x18	M6x16	M8x14	157.75	67	130	70.7	12	21.5	38.3	—	2
110	110	47	40	M10x18	M8x22	M10x18	196.5	74	165	85.0	14	27	45.3	—	2.5
130	130	55	50	M12x20	M8x14	M10x16	240	81	215	104	15	27	48.8	51.8	3

Dimensioni attacco flangia entrata

Dimensions of the input mounting flange

Abmessungen des Eintriebsflansches

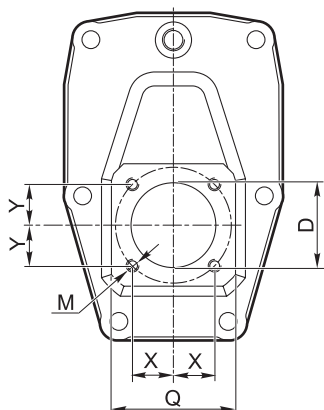

H	D	M	Q	X	Y
40	26	M5x9	40	12.5	12.5
50	32	M5x9	45	15	15
63	40	M6x12	53	19	19
75	47	M6x12	62	21.5	21.5
90	47	M6x12	62	21.5	21.5
110	52	M8x15	75	25	25
130	62	M10x17	92	30	30

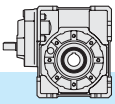

4.7 Dimensioni

4.7 Dimensions

4.7 Abmessungen

Flangia uscita / Output flange / Abtriebsflansch

Vista da A / View from A / Ansicht von A

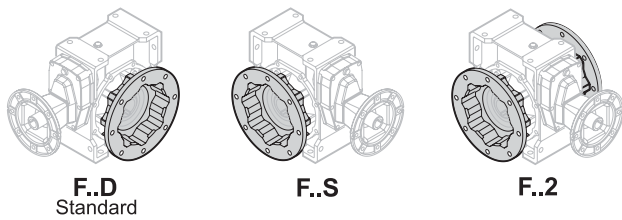
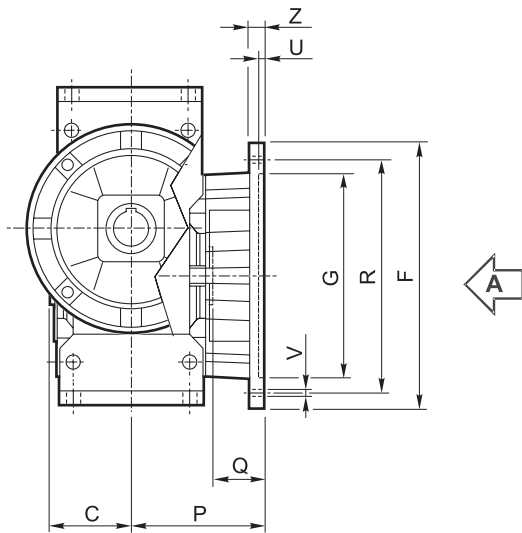

40	50		40	50
F1	F1		—	—
F2	—		—	F2
—	—		F3	—

40 - 50

63	75		63	75
F1	F1		—	—
F2	—		—	F2
—	—		F3	—

63 - 75

90	110	130		90	110
—	F1	F1		F1	—
—	—	—		F2	F2
—	—	—		F3	—

90 - 110

130		130
F1		—
F2		—
—		—

130

Tipo Type Typ	C	F		G H8	P	Q	R	U	V			Z
											Ø	
40	F1	39		85	60	67	28	75-90	4	n° 4	9	8
	F2			85	60	97	58	75-90	4	n° 4	9	8
	F3			140	95	80	41	115	5	n° 7	9	10
50	F1	46		94	70	90	44	85-100	5	n° 4	11	10
	F2			160	110	89	43	130	5	n° 7	11	11
	F3											
63	F1	56		142	115	82	26	150	5	n° 4	11	11
	F2			142	115	112	56	150	5	n° 4	11	11
	F3			160	110	80.5	24.5	130	5	n° 4	11	12
75	F1	60		160	130	111	51	165	5	n° 4	13	12
	F2			160	110	90	30	130	6	n° 4	11	13
	F3											
90	F1	70		200	152	111	41	175	5	n° 4	13	12
	F2			200	152	151	81	175	5	n° 4	13	13
	F3			200	130	110	40	165	6	n° 4	11	11
110	F1	77.5		260	170	131	53.5	230	6	n° 8	13	15
	F2			250	180	150	72.5	215	5	n° 4	15	16
	F3											
130	F1	85		320	180	140	55	255	7	n° 8 *	16	16
	F2			300	230		265					
	F3											

* Foratura ruotata di 22.5°

* Drilling turned of 22.5°

* Durchbohrung 22.5° versetzt

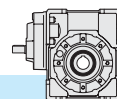

4.7 Dimensioni

4.7 Dimensions

4.7 Abmessungen

Flangia entrata / Input flange / Antriebsflansch

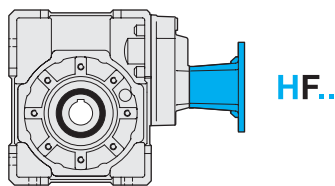

PM = 1

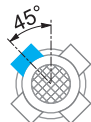

PM = 2

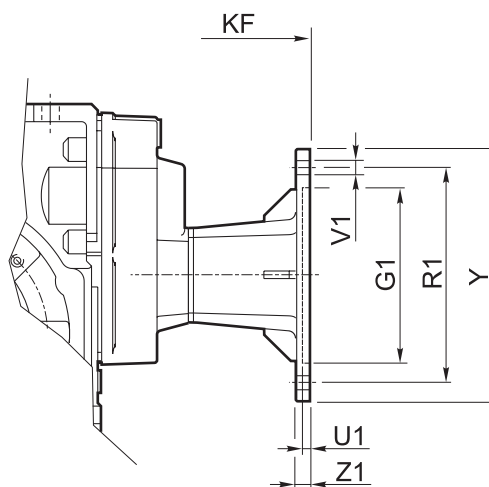

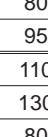
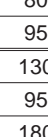
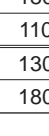
HF	IEC	PM		G ₁ H7	K _F	R ₁	U ₁	Ø	V ₁			Y	Z ₁
		1	2										
40	56 B5	•	•	80	129.5	100	3.5	7		8		120	8
	56 B14		•	50	129.5	65	3.5	6			4	80	8
	63 B5	•	•	95	132.5	115	4	9		8		140	10
	63 B14	•	•	60	132.5	75	3.5	6		8		90	8
50	56 B5	•	•	80	148.5	100	3.5	7		8		120	8
	63 B5	•	•	95	151.5	115	4	9		8		140	10
	63 B14	•	•	60	151.5	75	3.5	6		8		90	8
	71 B5	•	•	110	158.5	130	4.5	9		8		160	10
	71 B14	•	•	70	158.5	85	4	7		8		105	10
63	63 B5	•	•	95	173	115	4	9		8		140	10
	71 B5	•	•	110	180	130	4.5	9		8		160	10
	71 B14		•	70	180	85	3.5	7			4	105	10
	80 B5	•	•	130	190	165	4.5	11		8		200	10
	80 B14	•	•	80	190	100	4	7		8		120	10
75	71 B5	•	•	110	212	130	4.5	9		8		160	10
	80/90 B5	•	•	130	232	165	4.5	11		8		200	10
	80 B14	•	•	80	222	100	4	7		8		120	10
	90 B14	•	•	95	232	115	4	9		8		140	10
90	71 B5	•	•	110	222	130	4.5	9		8		160	10
	80/90 B5	••	•	130	242	165	4.5	11		8		200	10
	80 B14	•	•	80	232	100	4	7		8		120	10
	90 B14	•	•	95	242	115	4	9		8		140	10
110	80/90 B5	•	•	130	294.5	165	4.5	11		8		200	10
	90 B14		•	95	294.5	115	4	9			4	140	10
	100/112 B5	•	•	180	304.5	215	5	14		8		250	14
	100/112 B14	•	•	110	304.5	130	4.5	9		8		160	10
130	80/90 B5	•	•	130	345.5	165	4.5	11	4			200	12
	100/112 B5	•	•	180	355.5	215	5	14	4			250	14

N.B.: Il montaggio STD di P_M=2 solo quando non è possibile il montaggio STD di P_M=1.

N.B.: STD mounting of P_M=2 only if STD mounting of P_M=1 is not possible.

ANMERKUNG: STD Montage von P_M=2 nur wenn STD Montage von P_M=1 unmöglich ist.

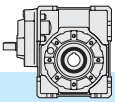

4.8 Entrata supplementare (vite bisporgente)

4.8 Additional input (double extended shaft)

4.8 Zusatzantrieb (beidseitige Welle)

S.e.A.

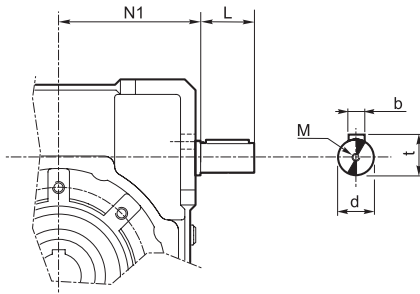

H	d j6	L	M	N1	b	t
40	11	20	M4x12	52.5	4	12.5
50	14	25	M5x13	62.5	5	16
63	19	30	M8x20	74.5	6	21.5
75	24	40	M8x20	91	8	27
90	24	40	M8x20	108	8	27
110	28	50	M8x20	132.5	8	31
130	38	70	M10x25	152	10	41

NOTA: L'entrata supplementare nella serie H si trova nella posizione intermedia del cinematismo. Quindi, se utilizzata come comando, avrà la sola riduzione della coppia vite/corona. Se invece viene utilizzata come asse condotto, la sua velocità sarà quella in entrata ridotta dal rapporto 4:1 della precoppia.

NOTE: the second shaft of the H series gearboxes is placed in the intermediate position of the kinematic motion which if used as a drive will have only the reduction of the worm/wheel set. For the utilization as a driven shaft its speed will correspond to the input speed reduced by the ratio 4:1 of the pre-stage.

BEMERKUNG: das zweite Wellenende der Getriebe der Serie H befindet sich in der Mitte des Getriebes. Falls das zweite Wellenende als zusätzliche Antriebswelle genutzt werden, muss aufgrund der Vorstufe mit einer um 4:1 reduzierte Drehzahl eingetrieben werden.

4.9 Limitatore di coppia cavo passante

4.9 Torque limiter with through hollow shaft

4.9 Drehmomentbegrenzer mit durchgehender Hohlwelle

Il limitatore di coppia viene consigliato in tutte quelle applicazioni che richiedono una limitazione sulla coppia trasmissibile per proteggere l'impianto e/o preservare il riduttore evitando sovraccarichi o urti indesiderati quanto inaspettati.

È un dispositivo con albero dotato di cavo passante, con funzionamento a frizione, ed è integrato al riduttore, presentando un ingombro limitato.

Concepito per lavorare a bagno d'olio, il dispositivo risulta affidabile nel tempo ed è esente da usura se non viene mantenuto in condizioni prolungate di slittamento (condizione che si verifica quando la coppia presenta valori superiori a quelli di taratura).

La taratura è facilmente regolabile dall'esterno attraverso il serraggio di una ghiera autobloccante che porta a compressione le 4 molle a tazza disposte tra loro in serie.

Il dispositivo non consente:

- l'impiego di cuscinetti a rulli conici in uscita
- funzionamento prolungato in condizioni di slittamento.

Nella tabella seguente vengono riportati i valori delle coppie di slittamento M_{2S} in funzione del n° di giri della ghiera.

I valori di taratura presentano una tolleranza del $\pm 10\%$ e si riferiscono ad una condizione statica.

In condizioni dinamiche è da notare che la coppia di slittamento assume valori diversi a seconda del tipo e/o modalità in cui si verifica il sovraccarico: con valori maggiori in caso di carico uniformemente crescente rispetto a valori più contenuti in seguito al verificarsi di picchi improvvisi di carico.

NOTA: quando si supera il valore di taratura si ha slittamento. Il coefficiente di attrito tra le superfici di contatto da statico diventa dinamico e la coppia trasmessa cala del 30% circa.

È quindi opportuno prevedere uno stop per poter ripartire al valore di taratura iniziale.

The use of a torque limiter is advisable in case of applications requiring the limitation of the torque in order to safeguard the plant and/or the gearbox against unexpected and undesired overloads or shocks.

The torque limiter is equipped with a through hollow shaft and friction clutch. It is integrated in the gearbox, space requirement is therefore limited.

Designed to work in oil bath, it is reliable over time and is not subject to wear unless prolonged slipping occurs (it happens when the torque values are higher than the calibration values).

Calibration can be easily adjusted from the outside by tightening of the self-locking ring nut, which causes the compression of 4 Belleville washers arranged in series.

The use of the torque limiter does not go together with:

- the use of tapered roller bearings at output
- Prolonged operation under slipping conditions.

The following table shows the values of M_{2S} slipping torques depending on the number of revolutions of the ring nut.

Calibration values feature a $\pm 10\%$ tolerance and refer to static conditions.

Under dynamic conditions, the values of the slipping torque differ depending to the type of overload: the values are higher if the load increase is uniform, the values are lower if sudden load peaks occur.

NOTE: Slipping occurs when the setting values are exceeded.

The friction coefficient between the contact surfaces from static becomes dynamic and the transmitted torque is approx. 30% lower.

It is advisable to have a stop first in order to have a restart based on the initial setting value.

Die Anwendung eines Drehmomentbegrenzers wird empfohlen, um die Anlage und das Getriebe gegen unerwünschte und unerwartete Überbelastungen und Stoßen zu schützen. Der Begrenzer verfügt über eine durchgehende Hohlwelle und eine Kupplung. Er ist in dem Getriebe integriert, d.h. der Raumbedarf ist klein.

Der Drehmomentbegrenzer wurde für Betrieb in Ölbad entworfen. Er ist zuverlässig über Zeit und verschleißfest (ausser wenn Rutschen für lange Zeit besteht: das passiert, wenn das Drehmoment höher als der Eichwert ist).

Die Eichung darf mühelos von aussen durch das Anziehen einer selbstsperrenden Mutter ausgeführt werden. Das Anziehen verursacht die Zusammendrückung der 4 wechselsinniggeschichteten Tellerfeder.

Die Vorrichtung sieht das folgende nicht vor:

- die Verwendung von Kegelerlenlager am Abtrieb
- Längerer Rutschbetrieb.

Die nachstehende Tabelle zeigt die Werte der Rutschmomente M_{2S} abhängig von der Zahl der Umdrehungen der Mutter.

Die Eichwerte weisen $\pm 10\%$ Toleranz auf und beziehen sich auf statische Bedingungen.

Unter dynamischen Bedingungen hat das Rutschmoment verschiedene Werte je nach Art der Überbelastung. Die Werte sind höher, wenn die Belastung gleichmäßig zunimmt; sie sind niedriger im Falle von plötzlichen Belastungsspitzen.

BEMERKUNG: Rutschen tritt auf, wenn die eingestellten Werte überschritten werden. Der Reibungskoeffizient zwischen den Berührungsflächen wird dynamisch anstatt statisch und das übertragene Drehmoment sinkt um ca. 30%.

Es ist daher ratsam, vor dem erneuten Anfahren anzuhalten, um die ursprünglichen Drehmomentwerte zu erreichen.

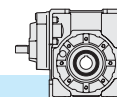

E' importante notare che la coppia di slittamento non resta sempre la medesima durante tutta la vita del limitatore.

Tende infatti a diminuire in rapporto al numero e alla durata degli slittamenti che, rodando le superfici di contatto, ne aumentano il rendimento.

È quindi opportuno verificare periodicamente, soprattutto durante la fase di rodaggio, la taratura del dispositivo.

Là dove sia richiesto un errore più contenuto nella taratura, è necessario testare la coppia trasmissibile sull'impianto.

Il dispositivo viene consegnato tarato alla coppia riportata a catalogo T_{2M} salvo diversa indicazione espressa in fase di ordinazione.

It is important to note that the slipping torque is not the same for the whole life of the torque limiter. It usually decreases in connection with the numbers and the duration of the slipping which because of the surfaces' lapping will increase the efficiency.

For this reason it is advisable to check the calibration of the device at regular intervals, specially during the running-in period.

Should a smaller calibration error be required, it is necessary to test the transmissible torque on the plant. The device is supplied already calibrated at the torque value reported in the catalogue T_{2M} , unless otherwise specified in the order.

Es ist wichtig zu beachten, dass das Rutschmoment über die gesamte Lebensdauer der Rutschkupplung nicht konstant bleibt, sondern üblicherweise in Verbindung mit längeren Rutschzyklen aufgrund der eingelaufenen Berührungsflächen abnimmt.

Deswegen ist es ratsam, die Eichung der Vorrichtung besonders während der Einlaufzeit zu prüfen.

Falls ein niedriger Eichfehler verlangt wird, ist das übersetzbare Drehmoment auf die Anlage zu testen. Wenn die Vorrichtung geliefert wird, ist sie schon auf dem im Katalog T_{2M} angegebenen Wert geeicht (ausser wenn es in der Bestellung anders angegeben wird).

H	N°. giri della ghiera di regolazione / N°. revolutions of ring nut / Nr. Umdrehungen der Mutter															
	1 1/4	1 1/2	1 3/4	2	2 1/4	2 1/2	2 3/4	3	3 1/4	3 1/2	3 3/4	4	4 1/4	4 1/2	4 3/4	5
	M_{2S} [Nm]															
40	37	45	48	52	60	65	67									
50		55	63	70	77	85	90	95	100	110	115	120				
63					110	125	137	150	163	175	183	190	203	215		
75		235	265	295	327	360										
90						275	297	320	350	380	415	450	485	520	535	550
110		550	600	700	750	800	850	920	970							
130																

Disposizione delle molle
Washers' arrangement
Lage der Feder

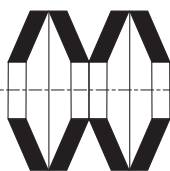

IN SERIE (min. coppia, max. sensibilità)
SERIES (min. torque, max sensitivity)
SERIE (min. Moment, max. Empfindlichkeit)

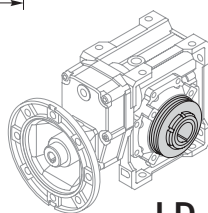
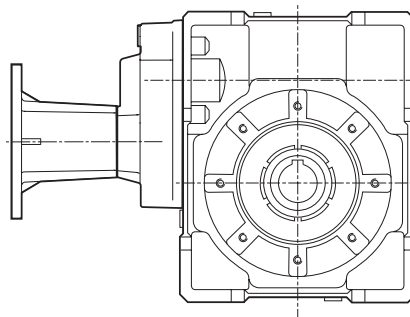
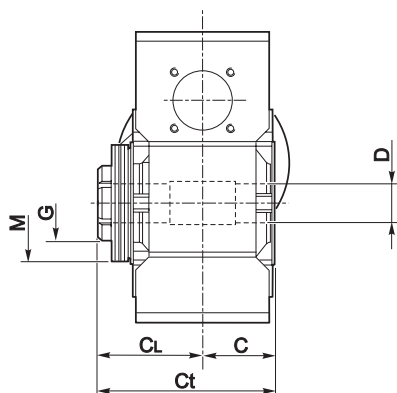

LD

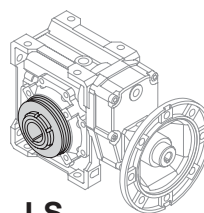

LS

H	C	C _L	C _t	D _{H7}	M	G
40	39	65	104	18 (19)	56x30.5x1.5	M30x1.5
50	46	76	122	25 (24)	63x40.5x1.8	M40x1.5
63	56	91	147	25	71x40.5x2	M40x1.5
75	60	100	160	28 (30)	90x50.5x3.5	M50x1.5
90	70	109	179	35 (32)	100x51x2.7	M50x1.5
110	77.5	127.5	205	42	125x61x4	M60x2.0
130						

() A richiesta / On request / Auf Anfrage

Nella versione con limitatore non è prevista la fornitura degli alberi lenti.

The version with torque limiter is supplied without output shafts.

Die Version mit Drehmomentbegrenzer wird ohne Abtriebswellen geliefert.

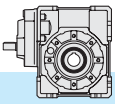

4.10 Accessori

4.10 Accessories

4.10 Accessories

Albero lento

Output shaft

Abtriebswelle

Albero lento semplice
Single output shaft
Standard Abtriebswelle

Albero lento doppio
Double output shaft
Doppelte Abtriebswelle

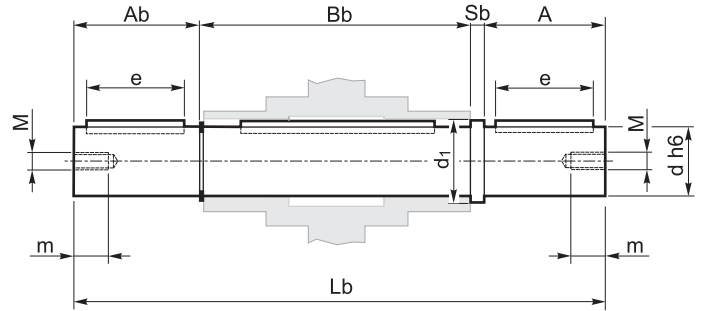
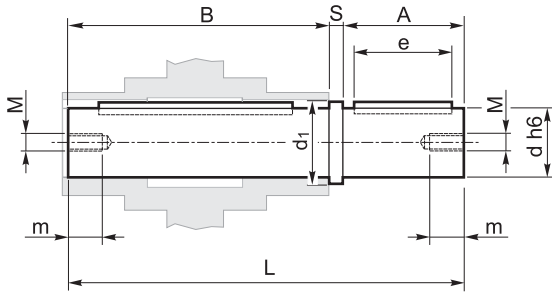

H	A	A _b	B	B _b	d _{h6}	d ₁	e	L	L _b	M	m	S	S _b
40	40	39	77	79	18	23.5	30	120	161	M6	16	3	3
50	50	49	90	93	25	31.5	40	143.5	199.5	M8	22	3.5	3.5
63	50	49	111	113	25	31.5	40	165	216	M8	22	4	4
75	60	59	119	121	28	34.5	50	183	244	M8	22	4	4
90	80	78.5	139	141.5	35	41.5	60	224	305	M10	28	5	5
110	80	77.5	154.5	157	42	49.5	60	242.5	322.5	M10	28	8	8
130	80	78	168	172	45	54.5	70	253	335	M16	36	5	5

Braccio di reazione

Torque arm

Drehmomentstütze

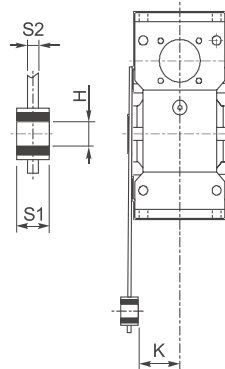
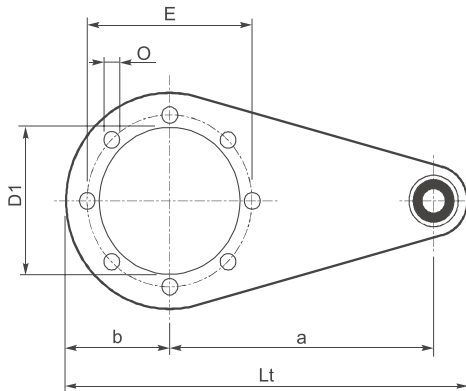

H	a	b	D ₁	E	H	K	L _t	O	S ₁	S ₂
40	100	45	60	75	10	31.5	167	7	14	4
50	100	50	70	85	10	39	172	9	14	5
63	150	55	80	95	10	49	227	9	14	6
75	200	70	95	115	20	47.5	302	9	25	6
90	200	80	110	130	20	57.5	312	11	25	6
110	250	100	130	165	25	62	390	11	30	6
130	250	125	180	215	25	69	415	13	30	6

Kit di protezione:

Protection Kit:

Schutzvorrichtung

Albero cavo / Hollow shaft / Hohlwelle

Limitatore di coppia / Torque limiter / Drehmomentbegrenzer

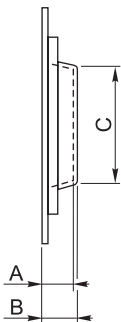

	A	B	C
40	14	15.5	44
50	15	16.5	54
63	17	19	60
75	18	20	70
90	21.5	24	80
110	22	25	96
130			

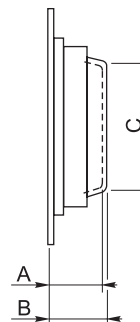

	A	B	C
40	40	41.5	44
50	47	48.5	53
63	52	54	55
75	58	60	68
90	60.5	63	70
110	72	75	85
130			

Opzioni disponibili:

Available options:

Auf Anfrage ist folgendes Zubehör erhältlich:

Cuscinetti a rulli conici corona

Tapered roller bearing for worm wheel

Kegelrollenlager für Schneckenrad

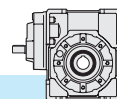

HA - HF

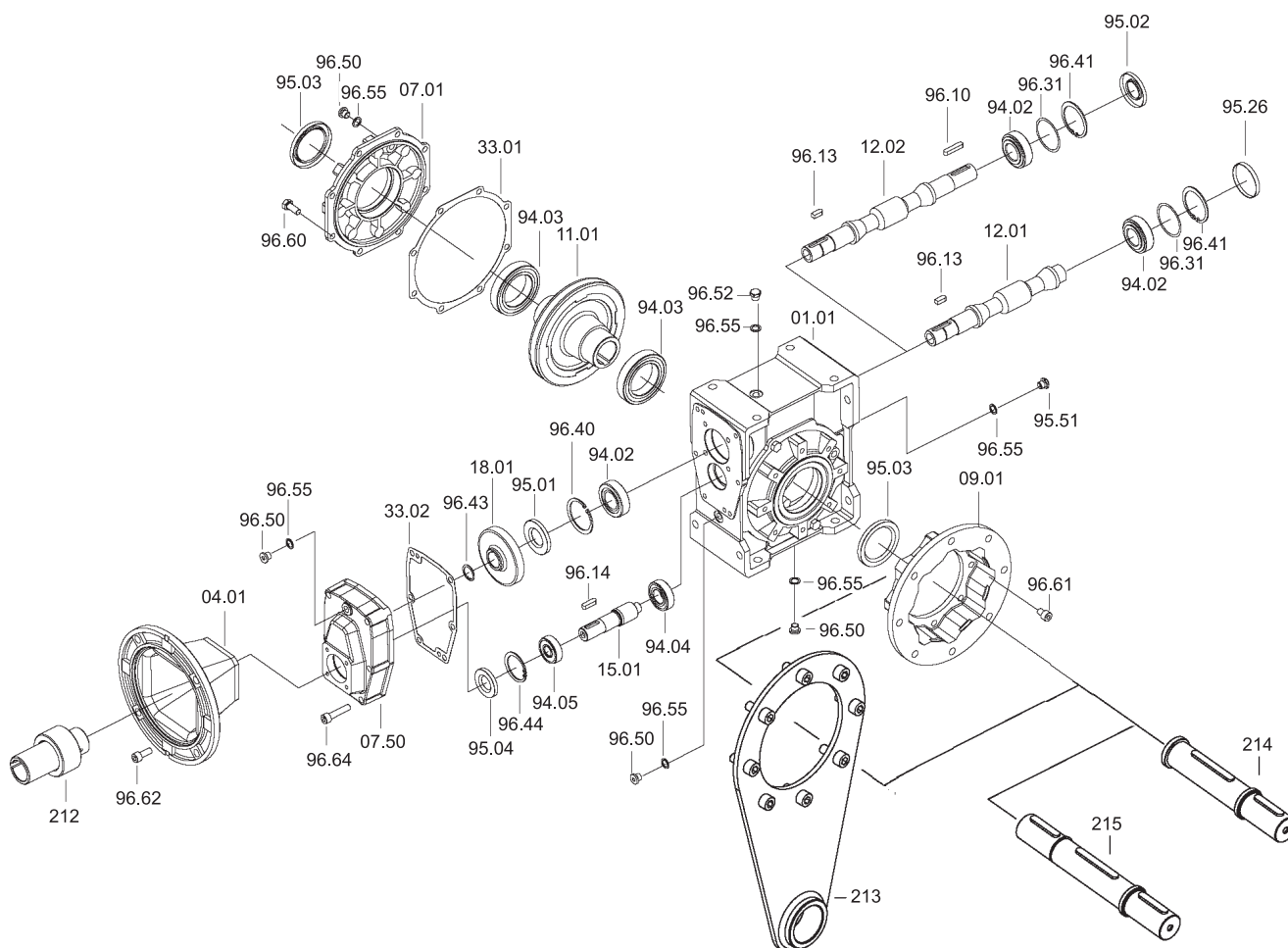

H	Cuscinetti / Bearings / Lager				Anelli di tenuta / Oilseals Öldichtungen				Cappello / Closed oil seal Geschlossene Öldichtung
	94.02	94.03	94.04	94.05	95.01	95.02	95.03	95.04	95.26
40	6201	6006	6000	6000	12/32/7	12/32/7	30/47/7	10/26/7	ø 32x7
	12x32x10	30x55x13	10x26x8	10x26x8					
50	6203	6008	6200	6201	17/40/7	17/40/7	40/62/8	12/32/7	ø 40x7
	17x40x12	40x68x15	10x30x9	12x32x10					
63	30204	6008	6201	6203	20/47/7	20/47/7	40/62/8	17/40/7	ø 47x7
	20x47x15.25	40x68x15	12x32x10	17x40x12					
75	30205	6010	6202	6204	25/52/7	25/52/7	50/72/8	20/47/7	ø 52x7
	25x52x16.25	50x80x16	15x35x11	20x47x14					
90	32205	6010	6202	6204	25/52/7	25/52/7	50/72/8	20/47/7	ø 52x7
	25x52x19.25	50x80x16	15x35x11	20x47x14					
110	32206B	6012	6303	6205	30/62/7	30/62/7	60/85/8	25/52/7	ø 62x7
	30x62x21.25	60x95x18	17x47x14	25x52x15					
130	33208	6015	6304	6305	40/80/10	40/80/10	75/100/10	25/62/8	ø 80x10
	40x80x32	75x115x20	20x52x15	25x62x17					

